

Platform Scales



Trade and Non-Trade Versions Available



Features

- Operation via Power, Battery or AC Adapter
- Auto Power Off



57mm 4 digit
Viewing Distance up to 25 metres

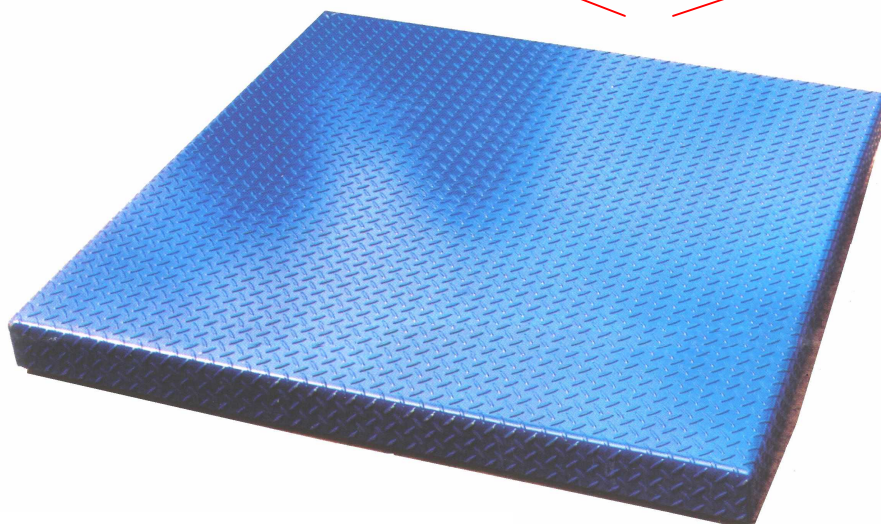

Features

- Strong robust design
- Very low profile design
- Access from all sides
- Can be used with a range of digital indicators
- Loading ramps can be added



Features

- Designed for Harsh Environments IP65
- Operation via Power, Battery or AC Adapter
- Auto Power Off



4 digits - 100mm high
Viewing distance up to 50 metres

Platform Scales



Trade and Non-Trade Versions Available

Models			
Max Capacity:	2 tonne.	3 tonne.	10 tonnes
Max Size mm	1200 x 1200	1500 x 1500	1500 x 1500
Finish	Painted	Galvanised Optional stainless top available	Painted / Stainless or galvanised
Non-standard sizes and capacities can be manufactured to your specifications.			

Options

- Drive on Ramp standard
- Drive on Ramp Drop Centre

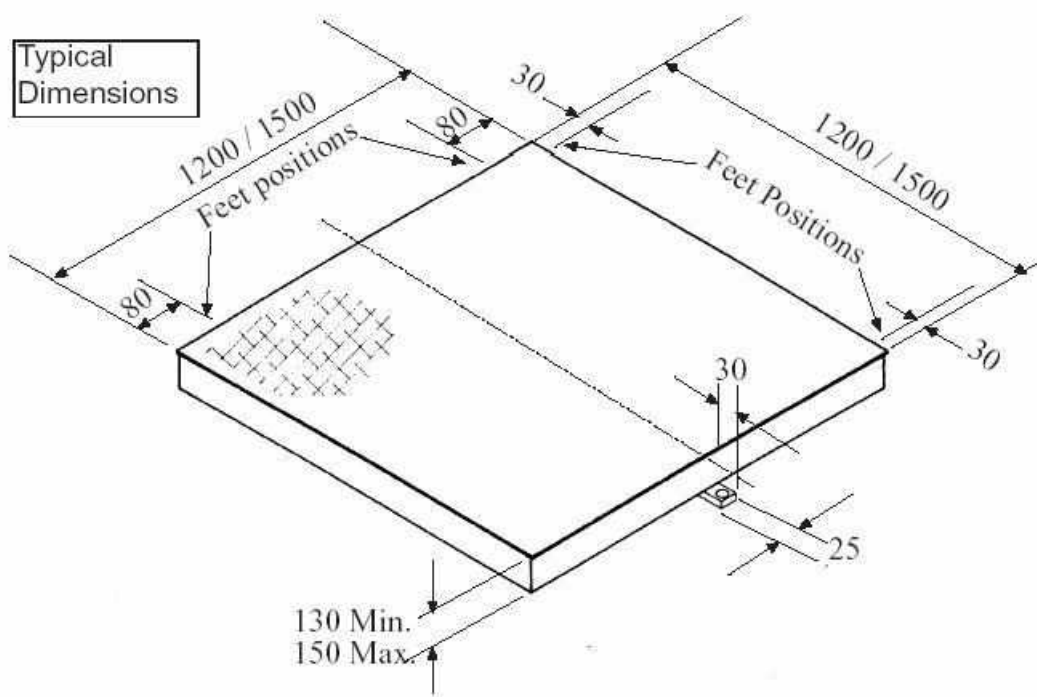

Specifications subject to change for improvement with out notice